



INSTALLATION DATA

720 SERIES

INTERMITTENT PILOT IGNITION GAS VALVES

The Robertshaw® 720 Series Gas Valves, for use on intermittent pilot ignition systems, are designed for a wide variety of applications. They incorporate a manual valve, pilot valve, dual automatic valves and a main gas pressure regulator.

The 720 valves have their pressure regulators factory pre-set at 3.5" W.C. for natural gas. Uni-Kit models can be converted to L.P. by installing the regulator conversion kit (included).

These valves feature wiring connections, manual selector and adjustments that are all easily accessible on top of the valve. With a 3-9/16" swing radius, the 720 Series lends itself well to replacing many O.E.M. valves. They are multiposition and can be mounted in any position (except upside down).

SPECIFICATIONS

Electrical Ratings	24 VAC, .45 amps
Pressure Regulator	
Natural Gas	factory set at 3.5" W.C.
L.P. Gas.....	factory set at 11.0" W.C.
Ambient Temperature	-40° to 175°F
Maximum Inlet Pressure	7" W.C. - natural gas
.....	14" W.C. - L.P. gas

REGULATION CAPACITIES

SIZE	TYPE GAS			
	NATURAL		L.P.	
	MIN.	MAX.	MIN.	MAX.
3/8" x 3/8"	15,000	175,000	15,000	280,000
1/2" x 3/8"	15,000	175,000	15,000	280,000
1/2" x 1/2"	15,000	200,000	15,000	320,000
1/2" x 3/4"	15,000	200,000	15,000	320,000
3/4" x 3/4"	15,000	200,000	15,000	320,000

INSTALLATION INSTRUCTIONS

Turn off gas supply and electrical power to equipment before servicing.

CAUTION
THIS DEVICE SHOULD BE INSTALLED BY A QUALIFIED TECHNICIAN WITH DUE REGARD FOR SAFETY AS IMPROPER INSTALLATION COULD RESULT IN A HAZARDOUS CONDITION.

PIPING

1. Check replacement valve for multiple outlets (side outlets). If it has them, be sure all unused outlets are plugged using the socket plugs provided.
2. Pipe or tubing must be clean and free of scale and dirt.
3. Make sure gas piping is pressure tested before control is connected. High pressure can damage control causing a hazardous condition. Do not subject control to more than 1/2 PSI, (14" W.C.) inlet pressure.

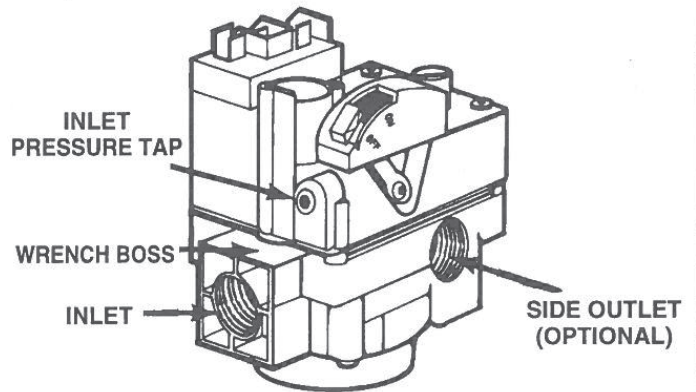
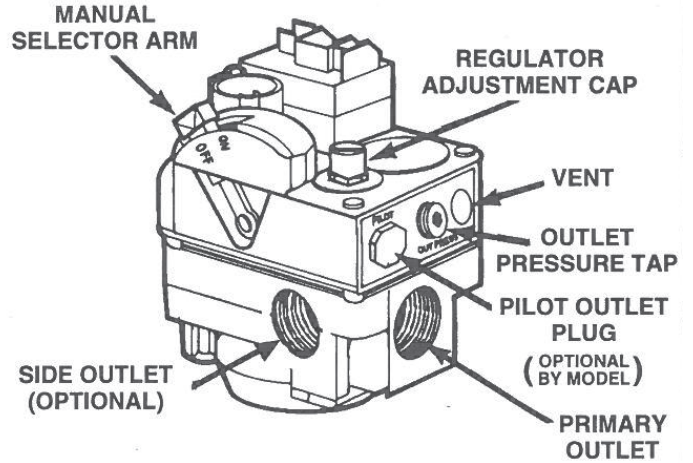

NOTE:

To prevent unsafe attempts at repair, special screws are used and replacement parts are NOT available.

4. If it's not already installed, a drip leg (sediment trap) must be added to the gas supply line to the control. (See figure below.) All piping must comply with local codes and ordinances and with National Fuel Gas Code (ANSI Z223.1/NFPA, No.54).

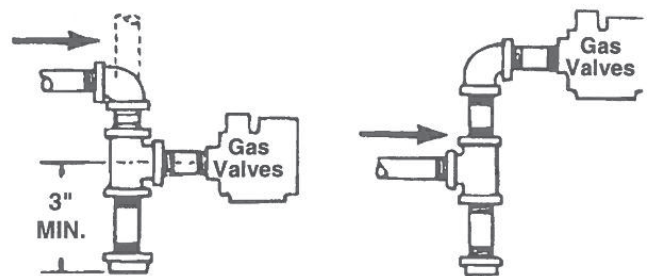

DRIP LEG

INSTALLATION INSTRUCTIONS (CON'T)

- Using pipe thread compound suitable for gas being used, apply a small amount on the male pipe threads. (Do not use Teflon tape or Teflon compound.) Leave the first two threads clean. Never use compound on female threads as it might be pushed into the control body.
- The gas valve is multiposition and can be mounted in any position (except upside down) without affecting its operation.
- Install gas valve so gas flow conforms with the inlet and outlet of the control.
- DO NOT** insert any object other than suitable pipe or tubing in the inlet or outlet of this control. Internal damage may occur and result in hazardous condition. A backup wrench should only be used on the wrench boss provided for this purpose (see drawing), never on body of the control, as this could distort the casting. **NOTE:** Do not overtighten any pipe connections, as this could crack the valve body. A valve with a cracked valve body will not be warrantied.

PRESSURE REGULATOR VENT

The 720 Series when equipped with a pressure regulator, has as standard equipment a built-in Vent Limiter. The regulator vent is tapped 1/8" tubing if vent tubing is required. **CAUTION:** If bleed tubing is used, do not allow main burner or pilot flame impingement on the tubing as this will eventually cause clogging of the tubing and improper regulator operation. If bleed tubing is not used, the regulator vent must be properly shielded from moisture.

LEAK TEST

Leak test with a soap solution after installing with main burner on. Coat pipe and tubing joints, gasket, etc. with soap solution. Bubbles indicate leaks.

WIRING

DO NOT short gas valve terminals. This will damage wall thermostat and void warranty.

- Check the system for the proper transformer by comparing the VA ratings of the transformer and the system. The system rating is determined by multiplying the voltage draw times the Amp draw. Normally 20VA transformers are sufficient for heating only applications and 40VA for heating/cooling applications.
NOTE: Improper transformer VA rating will cause erratic system operation.
- Connect the wire from the "MV" terminal on the ignition control unit to the "M" terminal on the gas valve.
- Connect the wire from the "PV" terminal on the ignition control unit to the "P" terminal on the gas valve.
- Connect the wire from the "MV/PV" terminal on the ignition control unit to the "C" terminal on the gas valve.

TYPICAL WIRING DIAGRAM

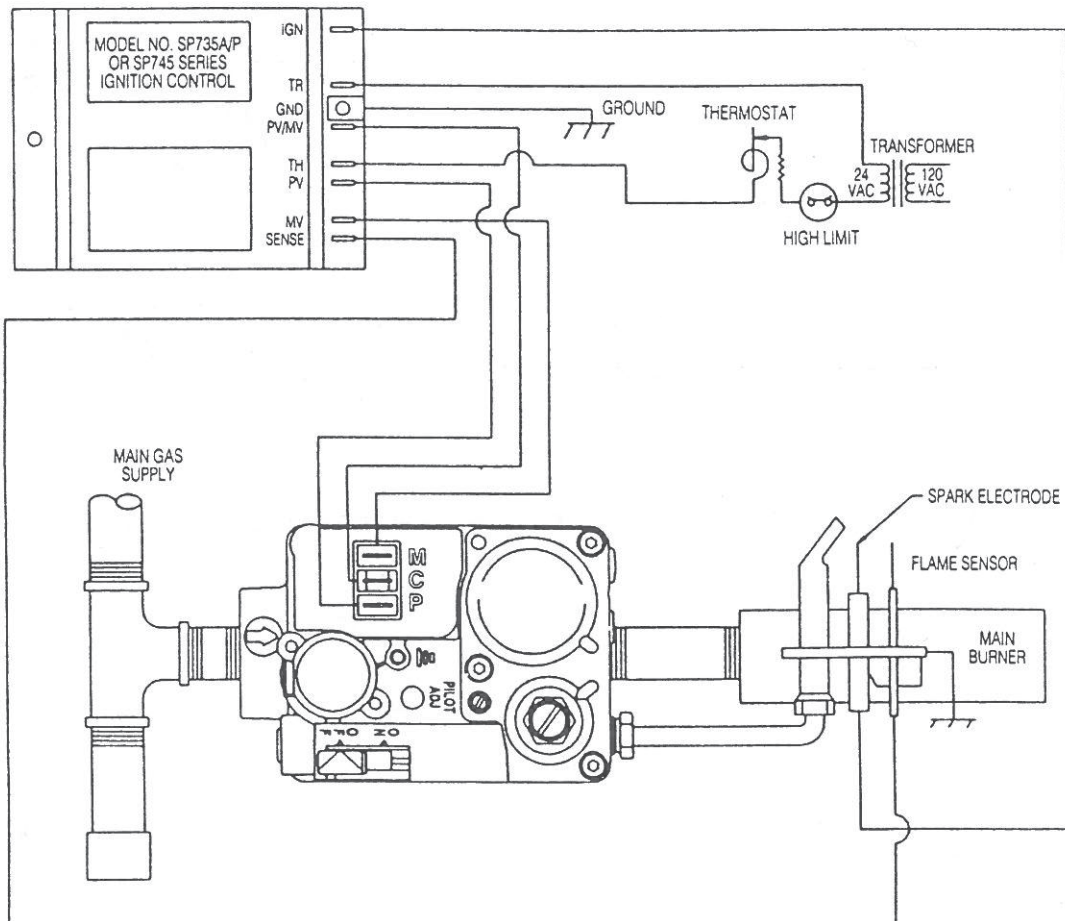

OPERATING INSTRUCTIONS



CAUTION

1. **WARNING:** If you do not follow these instructions exactly, a fire or explosion may result with property damage, personal injury or loss of life.
2. Smell all around the appliance area for gas. If the appliance uses L.P. (bottled) gas, also be sure to smell next to the floor because L.P. gas is heavier than air.
3. **WARNING:** If you smell gas, immediately shut off the manual valve in the gas piping to the appliance. Don't touch any electrical switch or use the phone. Leave the building and call your gas supplier. If he cannot be reached, call the fire department.
4. **WARNING:** Do not force the gas control knob on the appliance. Use only your hand to push down and/or to turn the gas control knob. Never use any tools. If the gas control knob will not operate by hand, the control should be replaced by a qualified service technician. Force or attempted repair may result in fire or explosion.
5. **WARNING:** The gas control must be replaced if it has been exposed to water.

1. Turn wall thermostat to its lowest setting. Remove burner access panel(s).
Selector arm must only be operated by hand (see below). **DO NOT** use pliers, wrenches or other tools to operate the arm. The selector arm cannot be moved into the "off" position without first depressing the lever to the "on" position.
2. Move selector arm to the "off" position. (See figure 1.)
3. **WARNING:** Wait at least 5 minutes to allow any gas in the combustion chamber to vent. If you then smell gas in the appliance area or near the floor, STOP and follow warning instructions above. Failure to do so may result in fire or explosion.
4. Move selector arm to the "on" position, (see figure 2), and set room thermostat to desired temperature. Allow burner to cycle on and off.
5. Replace burner access panel.

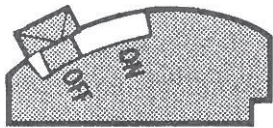

Figure 1

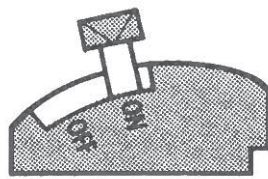

Figure 2

SERVICE INSTRUCTIONS

CAUTION: If control has been exposed to water in any way, it must be replaced. If gas valve fails to shut off, do not turn off electrical power. Turn off gas supply allowing fan or circulating pump (if so equipped) to continue running until system has cooled. Replace control.



WARNING

Servicing of gas controls, appliance and systems must be performed by qualified service personnel only.

PRESSURE REGULATOR ADJUSTMENTS

Adjustment of the pressure regulator is not normally necessary since it is preset at the factory. However, field adjustment may be accomplished as follows:

NOTE: Manometer attachment may be accomplished at pressure tap plug, above control outlet, as shown in figure to the right. If using inlet pressure tap to measure incoming pressure. See drawing on first page.

1. Manometer or gauge attachment may be accomplished at pressure tap plug (D).
2. Remove regulator adjustment screw cap (top of control -A).
3. With small screwdriver, rotate adjustment screw (B) clockwise to increase, or counterclockwise to decrease pressure to comply with manufacturer's specifications.
4. Replace regulator adjustment screw cap (A).

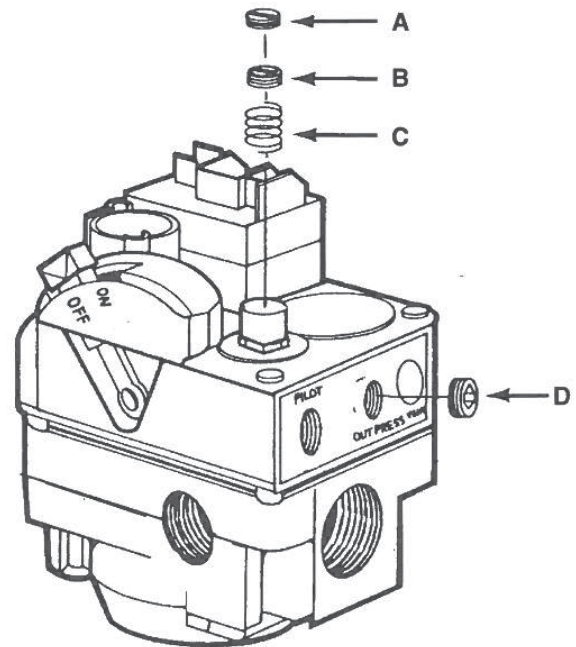

SERVICE INSTRUCTIONS (CON'T)

REGULATOR CONVERSION

CAUTION: Main burner and pilot orifices must be changed when regulator is converted from one type of gas to another.

The 720 Series Valves can be converted from natural to L.P. by installing the enclosed conversion kit. On models with step-opening feature, follow instructions packaged with the conversion kit (included in the Uni-Kit).

1. Turn off gas and electricity to appliance.
2. Remove slotted cap (A), adjusting screw (B), and natural gas spring not color coded - (C), from control.
3. Install new L.P. spring - color coded with a black strip.
4. Install new adjusting screw (B).
5. Attach manometer or pressure gauge at the outlet pressure tap (D).
6. Turn gas and electricity on.
7. Turn room thermostat to call for heat.
8. With burner on, adjust screw (B) to supply L.P. gas to pressure as recommended by the appliance manufacturer.
9. If adjusting screw (B) reaches its maximum depth (bottoms out) before recommended pressure setting is reached, turn screw counterclockwise until pressure drops slightly (approximately 0.1" W.C.) **WARNING:** Do not stretch or alter spring.
10. Turn off gas and electricity to appliance.
11. Remove manometer or pressure gauge and reinstall pressure tap outlet plug (D).
12. Install new red slotted cap in place of (A).
13. Turn gas and electricity on.
14. With burner operating, immediately check all fittings for leaks with soap solution. Bubbles indicate leaks that must be corrected.
15. Attach label to show control has been converted to L.P.
16. Set room thermostat to desired temperature.

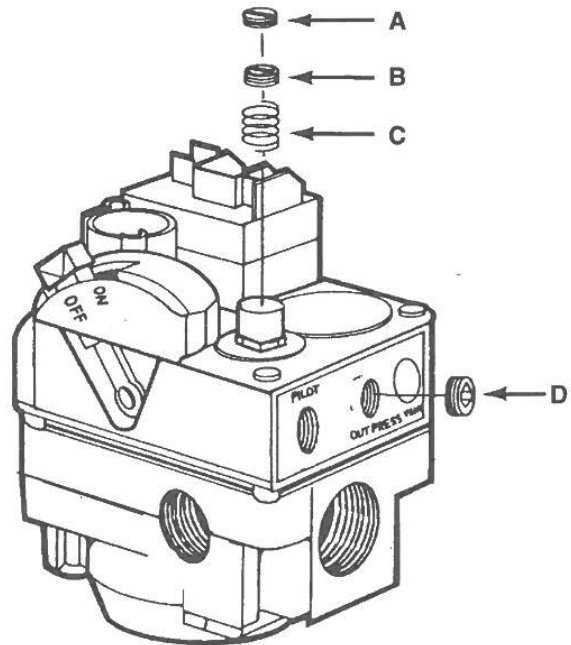

Customer Service Telephone 1.800.304.6563
Customer Service Facsimile 1.800.426.0804
HVACCustomerService@robertshaw.com

For Technical Service
Telephone 1.800.445.8299
Facsimile 1.630.260.7294
TechnicalService@robertshaw.com

Robertshaw®, Ranco®, Paragon® and Uni-Line® are trademarks of Robertshaw, its subsidiaries and/or affiliated companies. All other brands mentioned may be the trademarks of their respective owners.

www.uni-line.com
www.robertshaw.com
©2014 Robertshaw
09/14 -1-855 RevB