

Owner's Instruction and Operation Manual



Model Number:
EWVFS32(NV)(PV)



Report Number: 21-721

Certified for installations in the USA
Approved for installation in mobile homes

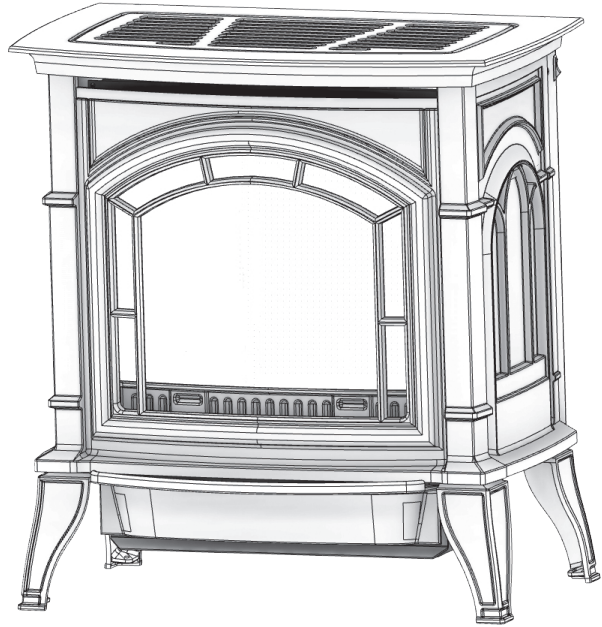

* All Pictures In This Manual Are For Illustrative Purposes Only. Actual Product May Vary.

854090-1002N

Save These Instructions In A Safe Place For Future Reference.

⚠ WARNING:

FIRE OR EXPLOSION HAZARD

Failure to follow safety warnings exactly could result in serious injury, death, or property damage.

Do not store or use gasoline or other flammable vapors and liquids in the vicinity of this or any other appliance.

WHAT TO DO IF YOU SMELL GAS:

- Do not try to light any appliance.
- Do not touch any electrical switch; do not use any phone in your building.
- Leave the building immediately.
- Immediately call your gas supplier from a neighbor's phone. Follow the gas supplier's instructions.
- If you cannot reach your gas supplier, call the fire department.

Installation and service must be performed by a qualified installer, service agency or the gas supplier.

Please read this manual BEFORE installing and operating this unit.

INSTALLER: Leave this manual with the appliance.

CONSUMER: Retain this manual for future reference.



CALIFORNIA PROPOSITION 65 WARNING:

This product can expose you to chemicals including carbon monoxide, which is known to the State of California to cause cancer, birth defects, and/or other reproductive harm. For more information, go to www.P65warnings.ca.gov

THIS MANUAL IS SUBJECT TO CHANGE WITHOUT NOTICE.

For more information, visit www.cuiheat.com PH. 800-845-5301

CODES

Adhere to all local codes or, in their absence, the latest edition of NFPA54.

NATIONAL
FIREPLACE
INSTITUTE



CERTIFIED
www.nficertified.org

We recommend that our gas hearth products be installed and serviced by professionals who are certified in the U.S. by the National Fireplace Institute® (NFI) as NFI Gas Specialists.

PLEASE READ THE INSTALLATION & OPERATING INSTRUCTIONS BEFORE USING APPLIANCE.

IMPORTANT:

READ ALL INSTRUCTIONS AND WARNINGS CAREFULLY BEFORE STARTING INSTALLATION. FAILURE TO FOLLOW THESE INSTRUCTIONS MAY RESULT IN A POSSIBLE FIRE HAZARD AND WILL VOID THE WARRANTY.

WARNING:

- ANY CHANGE TO THIS HEATER OR ITS CONTROLS CAN BE DANGEROUS.
- IMPROPER INSTALLATION OR USE OF THE HEATER CAN CAUSE SERIOUS INJURY OR DEATH FROM FIRE, BURNS, EXPLOSION OR CARBON MONOXIDE POISONING.
- DO NOT ALLOW FANS TO BLOW DIRECTLY INTO THE STOVE. AVOID ANY DRAFTS THAT ALTER BURNER FLAME PATTERNS.
- DO NOT USE A BLOWER INSERT, HEAT EXCHANGER INSERT OR OTHER ACCESSORY, NOT APPROVED FOR USE WITH THIS HEATER WHERE APPLICABLE.



WARNING: FIRE, EXPLOSION, AND ASPHYXIATION HAZARD

- IMPROPER ADJUSTMENT, ALTERATION, SERVICE, MAINTENANCE, OR INSTALLATION OF THIS HEATER OR ITS CONTROLS CAN CAUSE DEATH OR SERIOUS INJURY.
- READ AND FOLLOW INSTRUCTIONS AND PRECAUTIONS IN USER'S INFORMATION MANUAL PROVIDED WITH THIS HEATER.
- DO NOT ALLOW FANS TO BLOW DIRECTLY INTO THE STOVE. AVOID ANY DRAFTS THAT ALTER BURNER FLAME PATTERNS.
- DO NOT USE A BLOWER INSERT, HEAT EXCHANGER INSERT OR OTHER ACCESSORY, NOT APPROVED FOR USE WITH THIS HEATER WHERE APPLICABLE.

IMPORTANT:

READ THIS OWNER'S MANUAL CAREFULLY AND COMPLETELY BEFORE TRYING TO ASSEMBLE, OPERATE, OR SERVICE THIS APPLIANCE. IMPROPER USE OF THESE LOGS CAN CAUSE SERIOUS INJURY OR DEATH FROM BURNS, FIRE, EXPLOSION AND CARBON MONOXIDE POISONING.

IMPORTANT:

VENT-FREE HEATERS ADD MOISTURE TO THE AIR. ALTHOUGH THIS IS BENEFICIAL, INSTALLING THIS HEATER INTO ROOMS WITHOUT ADEQUATE VENTILATION MAY CAUSE MILDEW TO FORM FROM TOO MUCH MOISTURE.

RETAIN YOUR ORIGINAL RECEIPT FOR ANY WARRANTY CLAIMS. CONTACT YOUR DEALER OR INSTALLER IF YOU NEED TO FILE A CLAIM.

INSTALLATION CHECKLIST

Your gas stove should be installed by a qualified installer only. An NFI qualified Installer can be found at www.nficertified.org/public/find-an-nfi-pro/

For customer service, please contact your EverWarm dealer or visit www.cuiheat.com

COMMISSIONING CHECKLIST

This Checklist is to be completed in full by the qualified person who installs this unit. Keep this page for future reference.

Failure to install and commission according to the manufacturer's instructions and complete this checklist will invalidate the warranty.

Please Print

Customer Name:	Telephone Number:
Address:	
Model:	
Serial Number:	
Installation Company Name:	Phone Number:
Installation Technician's Name:	License Number:

DESCRIPTION OF WORK

Location of installed appliance: _____

COMMISSIONING

- Confirm proper placement of internal parts
- Check soundness of door gasket and door seals
- Confirm clearances to combustibles as per installation instructions in this manual
- Confirm the stove starts and operates properly.....
- Check to ensure a CO alarm is installed as per local building codes and is functional.....

Declaration of Completion: As the qualified person responsible for the work described above, I confirm that the appliance as associated work has been installed as per manufacturer's instructions and following any applicable building and installation codes.

Signed: _____ Print Name: _____ Date: _____

Home Owner: RETAIN THIS INFORMATION FOR FUTURE REFERENCE

REQUIREMENTS FOR THE COMMONWEALTH OF MASSACHUSETTS

This product must be installed by a licensed plumber or gas fitter when installed within the Commonwealth of Massachusetts.

NOTE REGARDING VENTED PRODUCTS

Flex line installation must not exceed 36 inches and must have a T shutoff valve. Any residence with a direct vent product must have a CO detector installed in the residence. Installation of the fireplace or vented gas log in the State of Massachusetts requires the damper to be permanently removed or welded in the fully open position. In addition, neither a naturally vented gas log nor a vent-free product may be installed in a bedroom or bathroom in the State of Massachusetts. All gas fitting and installation of this heater shall only be done by a licensed gas fitter or licensed plumber. For all side wall horizontally vented gas fueled equipment installed in every dwelling, building or structure used in whole or in part for residential purposes, including those owned or operated by the Commonwealth and where the side wall exhaust vent termination is less than seven (7) feet above finished grade in the area of the venting, including but not limited to decks and porches, the following requirements shall be satisfied:

INSTALLATION OF CARBON MONOXIDE DETECTORS

At the time of installation of the side wall horizontal vented gas fueled equipment, the installing plumber or gas fitter shall observe that a hard wired carbon monoxide detector with an alarm is installed on each additional level of the dwelling, building or structure served by the side wall horizontal vented gas fueled equipment. It shall be the responsibility of the property owner to secure the services of qualified licensed professionals for the installation of hard wired carbon monoxide detectors. In the event that the side wall horizontally vented gas fueled equipment is installed in a crawl space or an attic, the hard wired carbon monoxide detector with alarm and battery back-up may be

installed on the next adjacent floor level. In the event that the requirements of this subdivision can not be met at the time of completion of installation, the owner shall have a period of thirty (30) days to comply with the above requirements; provided, however, that during said thirty (30) day period, a battery operated carbon monoxide detector with an alarm shall be installed.

APPROVED CARBON MONOXIDE DETECTORS

Each carbon monoxide detector as required in accordance with the above provisions shall comply with NFPA 720 and ANSI/UL 2034 listed and IAS certified.

SIGNAGE

A metal or plastic identification plate shall be permanently mounted to the exterior of the building at a minimum height of eight (8) feet above grade directly in line with the exhaust vent terminal for the horizontally vented gas fueled heating appliance or equipment. The sign shall read, in print size no less than one-half (1/2) inch in size, "GAS VENT DIRECTLY BELOW, KEEP CLEAR OF ALL OBSTRUCTIONS".

INSPECTION

The state or local gas inspector of the side wall horizontally vented gas fueled equipment shall not approve the installation unless, upon inspection, the inspector observes carbon monoxide detectors and signage installed in accordance with the provisions of 248 CMR 5.08(2)(a)1 through 4.

Exemptions

The following equipment is exempt from 248 CMR 5.08(2)(a)1 through 4:

- The equipment listed in Chapter 10 entitled "Equipment Not Required To Be Vented" in the most current edition of NFPA 54 as adopted by the Board; and
- Product Approved side wall horizontally vented gas fueled equipment installed in a room or structure separate from the dwelling, building or structure used in whole or in part for residential purposes.

GAS EQUIPMENT VENTING SYSTEM PROVIDED

When the manufacturer of Product Approved side wall horizontally vented gas equipment provides a venting system design or venting system components with the equipment, the instructions provided by the manufacturer for installation of the equipment and the venting system shall include:

- Detailed instructions for the installation of the venting system design or the venting system components; and
- A complete parts list for the venting system design or venting system.

GAS EQUIPMENT VENTING SYSTEM NOT PROVIDED

When the manufacturer of a Product Approved side wall

horizontally vented gas fueled equipment does not provide the parts for venting the flue gases, but identifies “special venting systems”, the following requirements shall be satisfied by the manufacturer:

- The referenced “special venting system” instructions shall be included with the appliance or equipment installation instructions; and
- The “special venting systems” shall be Product Approved by the Board, and the instructions for that system shall include a parts list and detailed installation instructions.

A copy of all installation instructions for all Product Approved side wall horizontally vented gas fueled equipment, all venting instructions, all parts lists for venting instructions, and/or all venting design instructions shall remain with the appliance or equipment at the completion of the installation.

SAFETY INFORMATION

1. Due to high temperatures, the appliance should be located out of traffic and away from furniture and draperies.
2. Children and adults should be alerted to the hazard of high surface temperature and should stay away to avoid burns or clothing ignition.
3. Young children should be carefully supervised when they are in the same room with the appliance.
4. Do not place clothing or other flammable material on or near the appliance.
5. Any safety screen or guard removed for servicing an appliance, must be replaced prior to operating the heater.
6. Installation and repair should be done by a qualified service person.
7. To prevent malfunction and/or sooting, an unvented gas heater should be cleaned before use and at least annually by a professional service person. More frequent cleaning may be required due to excessive lint from carpeting, bedding material, etc. It is imperative that control compartments, burners and circulating air passageways be kept clean.
8. **CARBON MONOXIDE POISONING:** Early signs of carbon monoxide poisoning are similar to the flu with headaches, dizziness and/or nausea. If you have these signs, obtain fresh air immediately. Have the heater serviced as it may not be operating properly.
9. The installation must conform with local codes or, in the absence of local codes, with the National Fuel Gas Code, ANSI Z223.1/NFPA54.
10. This unit complies with the latest edition of ANSI Z21.11.2-2019, Unvented Heaters.
11. Do not install heater in a bathroom or bedroom unless approved for bedroom use.
12. Correct installation of the ceramic fiber logs, proper location of the heater, and annual cleaning are necessary to avoid potential problems with sooting. Sooting, resulting from improper installation or operation, can settle on surfaces outside the fireplace. See log placement instructions for proper installation.
13. Avoid any drafts that alter burner flame patterns. Do not allow fans to blow directly into fireplace. Do not place a blower inside burn area of firebox. Ceiling fans may create drafts that alter burner flame patterns. Sooting and improper burning will occur.
14. Caution: Candles, incense, oil lamps, etc. produce combustion by-products including soot. Vent-free appliances will not filter or clean soot produced by these types of products. In addition, the smoke and/or aromatics (scents) may be reburnt in the vent-free appliance which can produce odors. It is recommended to minimize the use of candles, incense, etc. while the vent-free appliance is in operation.

15. This is an unvented gas-fired heater. It uses air (oxygen) from the room in which it is installed. Provisions for adequate combustion and ventilation air must be provided.
16. This heater shall not be installed in a room or space unless the required volume of indoor combustion air is provided by the method described in the National Fuel Gas Code, ANSI Z223.1/NFPA 54, the International Fuel Gas Code or applicable local codes.
17. An unvented room heater having an input rating of more than 10,000 Btu per hour shall not be installed in a bedroom or bathroom.
18. Keep room area clear and free from combustible materials, gasoline and other flammable vapors and liquids.
19. Unvented gas heaters are a supplemental zone heater. They are not intended to be a primary heating appliance.
20. Unvented gas heaters emit moisture into the living area. In most homes of average construction, this does not pose a problem. In houses of extremely tight construction, additional mechanical ventilation is recommended.
21. During manufacturing, fabricating and shipping, various components of this appliance are treated with certain oils, films or bonding agents. These chemicals are not harmful but may produce annoying smoke and smells as they are burned off during the initial operation of the appliance; possibly causing headaches or eye or lung irritation. This is a normal and temporary occurrence. The initial break-in operation should last two to three hours with the burner at the highest setting. Provide maximum ventilation by opening windows or doors to allow odors to dissipate. Any odors remaining after this initial break-in period will be slight and will disappear with continued use.
22. Input ratings are shown in BTU per hour and are for elevations up to 2,000 feet. For elevations above 2,000 feet, input ratings should be reduced 4% for each 1,000 feet above sea level. Refer to the National Fuel Gas Code.
23. The appliance and its appliance main gas valve must be disconnected from the gas supply piping system during any pressure testing of that system at test pressures in excess of 1/2 psig (3.5 kPa).
24. The appliance must be isolated from the gas supply piping system by closing its equipment shutoff valve during any pressure testing of the gas supply piping system at test pressures equal to or less than 1/2 psig (3.5 kPa).
25. Do not use this room heater if any part has been under water. Immediately call a qualified service technician to inspect the room heater and to replace any part of the control system and any gas control which has been under water.
26. Never burn solid fuels in an unvented room heater, fireplace or stove.
27. Do not set kettles or humidifying devices on top of stove.
28. The stove door/screen must be closed when the appliance is operating. The screen shall have openings for induction of combustion air.

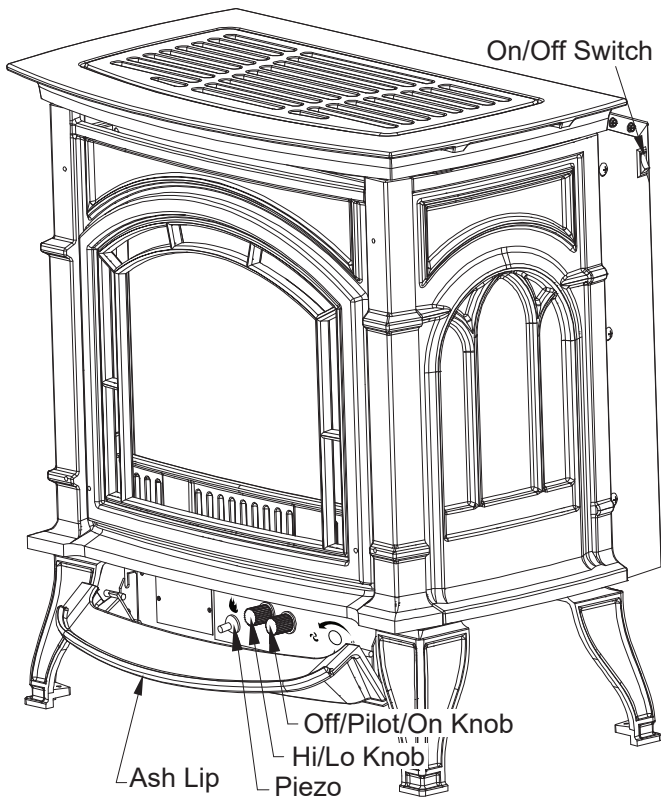

IGNITION CONTROLS

Piezo ignitor allows ignition of the pilot without the use of matches.

Millivolt control has four (4) positions:	
OFF	All gas to the burner is shut off at the valve.
IGN	Valve position to light/maintain a standing pilot.
ON	Valve position to turn burners on/off.
LOW/HI	Variable position to control flame height (heat output). Both front and rear burners are in operation to provide realistic glow and yellow flame.

PILOT / ODS

The gas log heater is fitted with a specially designed safety pilot (ODS assembly) light which senses the amount of oxygen available in the room and shuts the gas log heater off if the oxygen level begins to drop below a satisfactory level. The pilot can only be relit when adequate fresh air is available.

Gas Pressures		
	Natural	Propane (LP)
Regulator Pressure	3.5" w.c.	10.0" w.c.
Max. Gas Inlet Pressure	10.5" w.c.	13.0" w.c.
Min. Gas Inlet Pressure	5.0" w.c.	11.0" w.c.

Fuel	Control	Max. Input BTU/h	Min. Input BTU/h
Nat.	Millivolt	32,000	23,000
LP	Millivolt	32,000	23,000

WARNING:
THIS APPLIANCE IS EQUIPPED FOR (NATURAL OR PROPANE) GAS. FIELD CONVERSION IS NOT PERMITTED.

NOTE: An external regulator is required to reduce supply pressure to a maximum of 10.5" w.c. on Natural Gas systems operating at higher pressure.

NOTE: An external regulator is required to reduce supply pressure to a maximum of 13.0" w.c. for LP systems.

DIMENSIONS

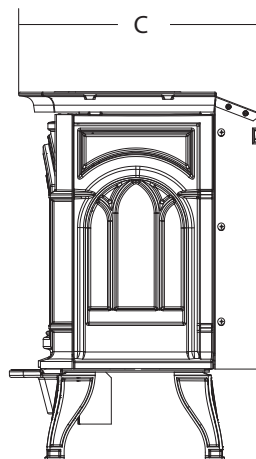
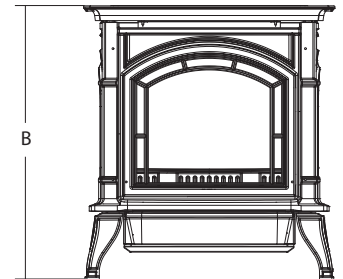
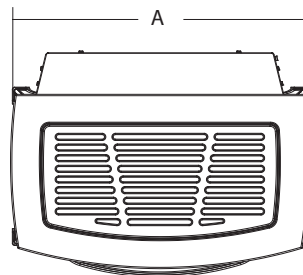

A	26" (660mm)
B	29" (737mm)
C	16" (406mm)

CAUTION:

GLOVES ARE RECOMMENDED WHEN HANDLING CERAMIC FIBER LOGS TO PREVENT SKIN IRRITATION FROM LOOSE FIBERS. LOGS ARE FRAGILE — HANDLE WITH CARE.

MAKE SURE YOU HAVE RECEIVED ALL PARTS

Check your packing list to verify that all listed parts have been received. You should have the following:

- Cast Iron Stove with Burner Assembly
- Installation/Operating Instructions
- Ceramic Fiber Logs

Carefully inspect the contents for shipping damage. If any parts are missing or damaged, immediately inform the dealer from whom you purchased the appliance. Do not attempt to install any part of the appliance unless you have all parts in good condition.

WHAT THE GAS TECHNICIAN WILL NEED FOR INSTALLATION

You must have the following items available before proceeding with installation:

- External regulator (for Propane/LPG) or high pressure natural gas (1 to 2 psi system)
- Piping which complies with local codes

- Sediment trap (recommended)
- Pipe wrench
- Pipe sealant approved for use with propane/LPG (resistant to sulfur compounds)
- Manual shutoff valve
- Tee joint
- Screwdrivers

WARNING:

DO NOT INSTALL THE HEATER ...

- **WHERE CURTAINS, FURNITURE, CLOTHING, OR OTHER FLAMMABLE OBJECTS ARE LESS THAN 42" FROM THE HEATER.**
- **IN HIGH TRAFFIC AREAS.**
- **IN WINDY OR DRAFTY AREAS.**

WARNING:

IF THE AREA IN WHICH THE HEATER MAY BE OPERATED DOES NOT MEET THE REQUIRED VOLUME FOR INDOOR COMBUSTION AIR, COMBUSTION AND VENTILATION AIR SHALL BE PROVIDED BY ONE OF THE METHODS DESCRIBED IN THE NATIONAL FUEL GAS CODE, ANSI Z223.1/NFPA 54, THE INTERNATIONAL FUEL GAS CODE OR APPLICABLE LOCAL CODES.

CLEARANCES AND HEIGHT REQUIREMENTS

WARNING:
 THE DIMENSIONS SHOWN ARE MINIMUM CLEARANCES TO MAINTAIN IN INSTALLING THIS HEATER. LEFT AND RIGHT CLEARANCES ARE DETERMINED WHEN FACING THE FRONT OF THE HEATER. FOLLOW THESE INSTRUCTIONS CAREFULLY TO ENSURE SAFE INSTALLATION. FAILURE TO FOLLOW INSTRUCTIONS EXACTLY CAN CREATE A FIRE HAZARD. THE APPLIANCE CANNOT BE INSTALLED ON A CARPET, TILE OR OTHER COMBUSTIBLE MATERIAL. THE APPLIANCE SHALL BE INSTALLED ON A NONCOMBUSTIBLE MATERIAL PANEL EXTENDING THE FULL WIDTH AND DEPTH OF THE APPLIANCE.

A	Min Ceiling From Floor	72"
B	Mantel Depth (maximum protrusion)	12"
C	Top of Unit to Mantel (minimum height)	18"
D	Minimum to a Side Wall	2"
E	Rear Measured From Back	1"
F	Corner Measured From Top Corners	1/2"

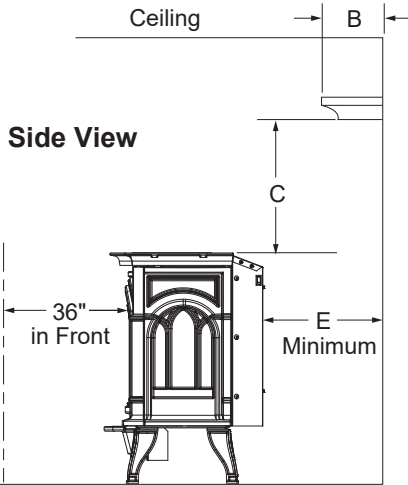
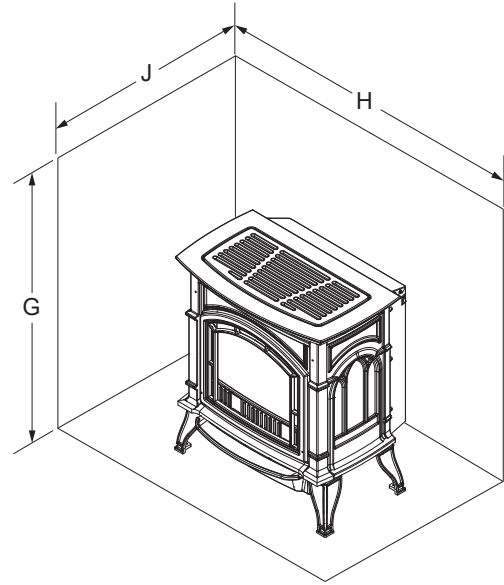
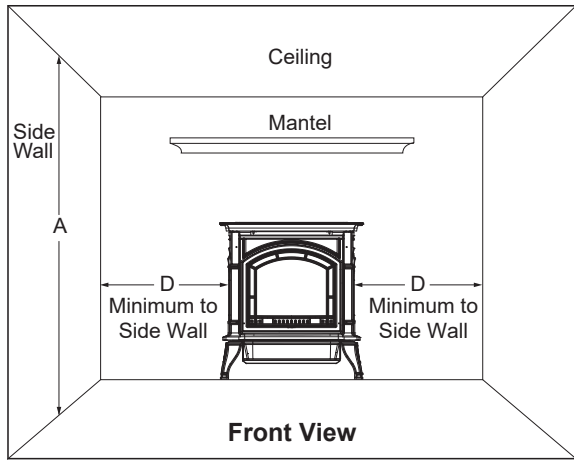

Alcove Minimum Dimensions		
G	Height From Hearth	52"
H	Width	34"
J	Depth	36"

NOTE: Maintain minimum side and back clearances when placing stove in alcove.

ATTENTION:
 MAINTAIN LISTED CLEARANCES FOR ANY REQUIRED SERVICING AND FOR PROPER OPERATION OF THIS APPLIANCE.

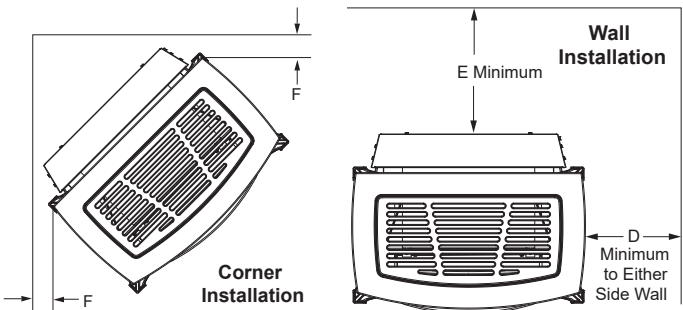

CAUTION!

THE APPLIANCE IS VERY HEAVY. THE ASSISTANCE FROM A SECOND PERSON IS STRONGLY SUGGESTED. PLEASE USE PROPER LIFTING TECHNIQUE WHEN POSITIONING THE APPLIANCE FOR ASSEMBLY AND INSTALLATION.

1. Remove the two (2) straps, and open the wrapping. Slide the bag to the bottom of the unit.

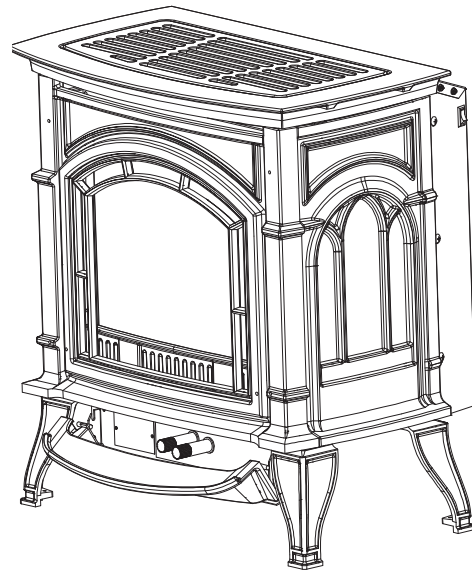
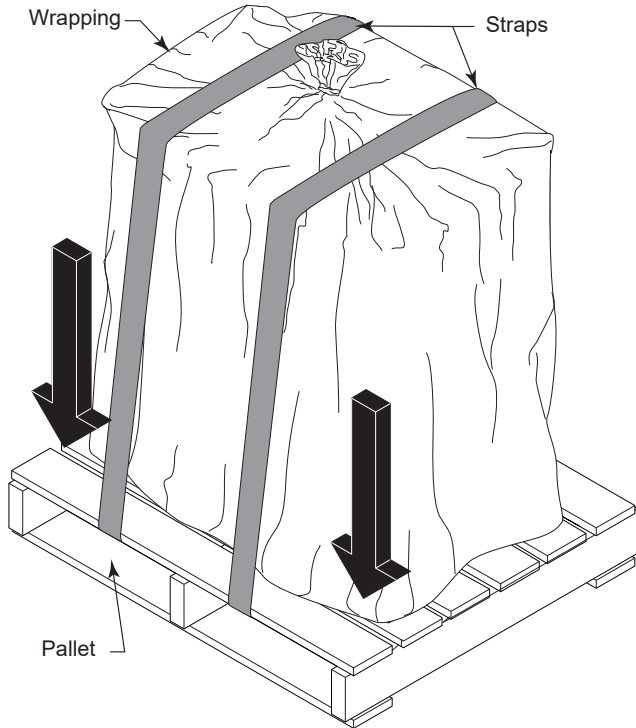

3. Lift the front of the stove, pivot the bottom outwards, and then gently pull down to detach the front panel.

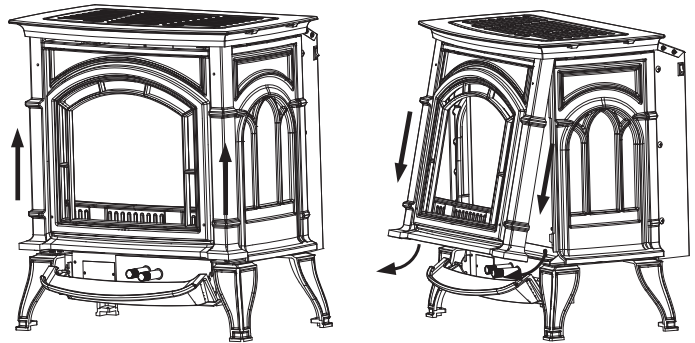

2. Lift the ash lip up to disengage. Rotate the ash lip away from the unit and downward to open the control door.

4. Remove the two screws located at the bottom of the screen as shown. Lift up and back on the screen to remove.

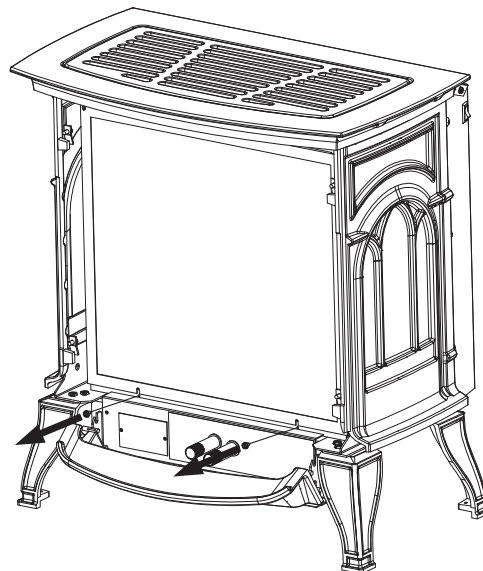
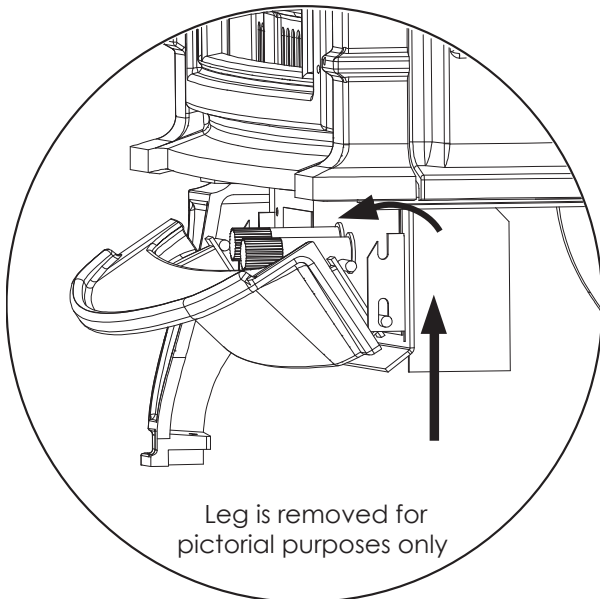

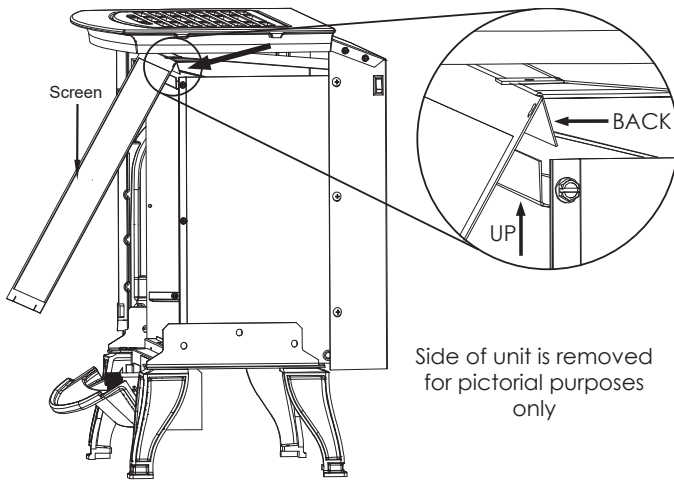

5. Remove the log box from inside the unit. Lift the unit off the pallet. **NOTE:** Make sure to lift the unit up high enough to clear the upright supports the unit is sitting on.

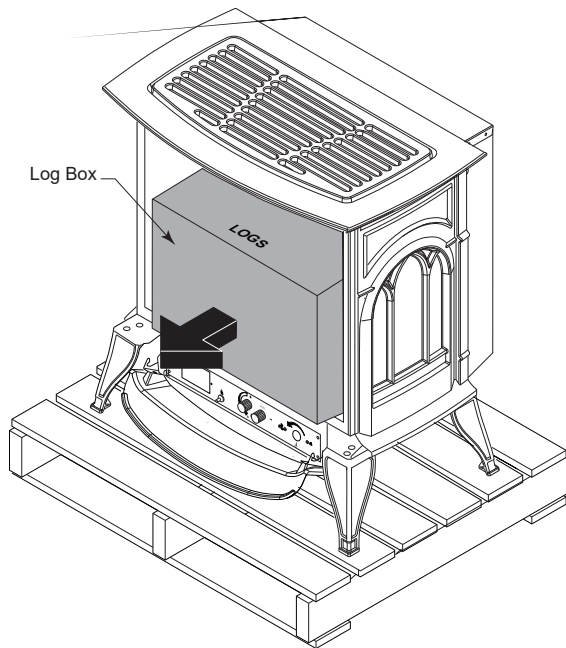

6. Reverse steps 2-4 to reinstall the screen and front of the stove.

CAUTION:

THE APPLIANCE IS VERY HEAVY. THE ASSISTANCE FROM A SECOND PERSON IS STRONGLY SUGGESTED. PLEASE USE PROPER LIFTING TECHNIQUE WHEN POSITIONING THE APPLIANCE FOR ASSEMBLY AND INSTALLATION.

MODEL #: B150 - ROOM BLOWER (sold separately)

A room blower to help with air circulation is available for purchase, if not provided with your unit. Contact your dealer for details or visit us at www.cuiheat.com. For installation, follow the instructions provided with the blower kit.

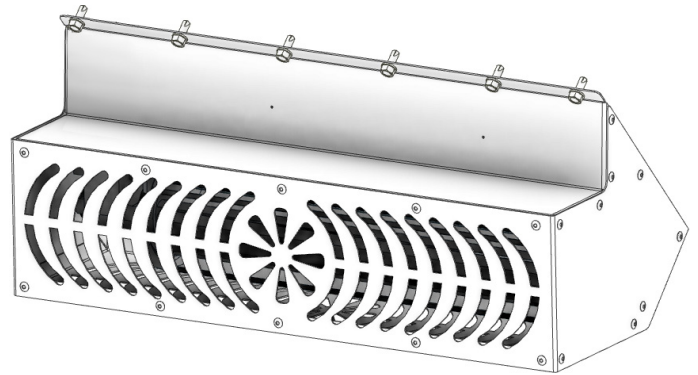

WARNING:

USE NEW BLACK IRON OR STEEL PIPE. INTERNALLY TINNED COPPER OR COPPER TUBING CAN BE USED PER NATIONAL FUEL CODE, SECTION 2.6.3, PROVIDING GAS MEETS HYDROGEN SULFIDE LIMITS, AND WHERE PERMITTED BY LOCAL CODES. GAS PIPING SYSTEM MUST BE SIZED TO PROVIDE MINIMUM INLET PRESSURE (LISTED ON DATA PLATE) AT THE MAXIMUM FLOW RATE (BTU/HR). UNDUE PRESSURE LOSS WILL OCCUR IF THE PIPE IS TOO SMALL.

A MANUAL SHUTOFF VALVE MUST BE INSTALLED UPSTREAM OF THE APPLIANCE. UNION TEE AND PLUGGED 1/8" NPT PRESSURE TAPPING POINT SHOULD BE INSTALLED UPSTREAM OF THE APPLIANCE. A SEDIMENT TRAP SHOULD BE INSTALLED UPSTREAM TO PREVENT MOISTURE AND CONTAMINANTS FROM PASSING THROUGH THE PIPE TO APPLIANCE CONTROLS AND BURNERS. FAILURE TO DO SO COULD PREVENT THE APPLIANCE FROM OPERATING RELIABLE.

NOTICE: A qualified gas appliance installer must connect the heater to the gas supply. Consult all local codes.

IMPORTANT: Hold heater valve firmly with a wrench to prevent movement when connecting to inlet pipe. Always use an external regulator for all propane/LPG heaters and high pressure one to two-pound systems only, to reduce the supply tank pressure to a maximum of 13" w.c. This is in addition to the internal regulator in the heater valve.

CHECK GAS TYPE: The gas supply must be the same as stated on the heater's rating plate. If the gas supply is different, DO NOT INSTALL THE HEATER. Contact your dealer for the correct model.

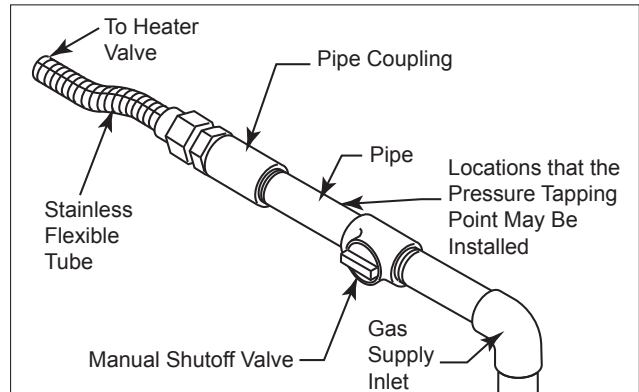

ELECTRICAL WIRING (MILLIVOLT)

The millivolt valve is a self-powered combination gas control THAT DOES NOT REQUIRE 110V AC TO OPERATE.

CAUTION:

LABEL ALL WIRES PRIOR TO DISCONNECTION WHEN SERVICING CONTROLS. WIRING ERRORS CAN CAUSE IMPROPER AND DANGEROUS OPERATION. VERIFY PROPER OPERATION AFTER SERVICING.

CHECK SYSTEM OPERATION

The millivolt system and individual components may be checked with a millivolt meter having a 0-1000 mV range. Conduct each check shown in the following chart by connecting meter test leads to terminals as indicated.

- | |
|--|
| A. Complete Millivolt System Check ("A" Reading - Thermostat contacts closed - Control Knob "ON" - Main burner should turn on) |
| <ul style="list-style-type: none"> If the reading is more than 100 millivolts and the automatic valve still does not come on, replace the control. If the closed circuit reading ("A" reading) is less than 100 millivolts, determine cause for low reading, proceed to section B below. |
| B. Thermopile Output Reading Check ("B" Reading - Thermostat contacts open - Main burner off) |
| <ul style="list-style-type: none"> Check gas pressure to the unit. If gas pressure is within minimum and maximum on data plate, then check thermopile voltage, 325 millivolts minimum. If the minimum millivolt reading is not obtainable, replace pilot. |

ELECTRICAL WIRING (MILLIVOLT)

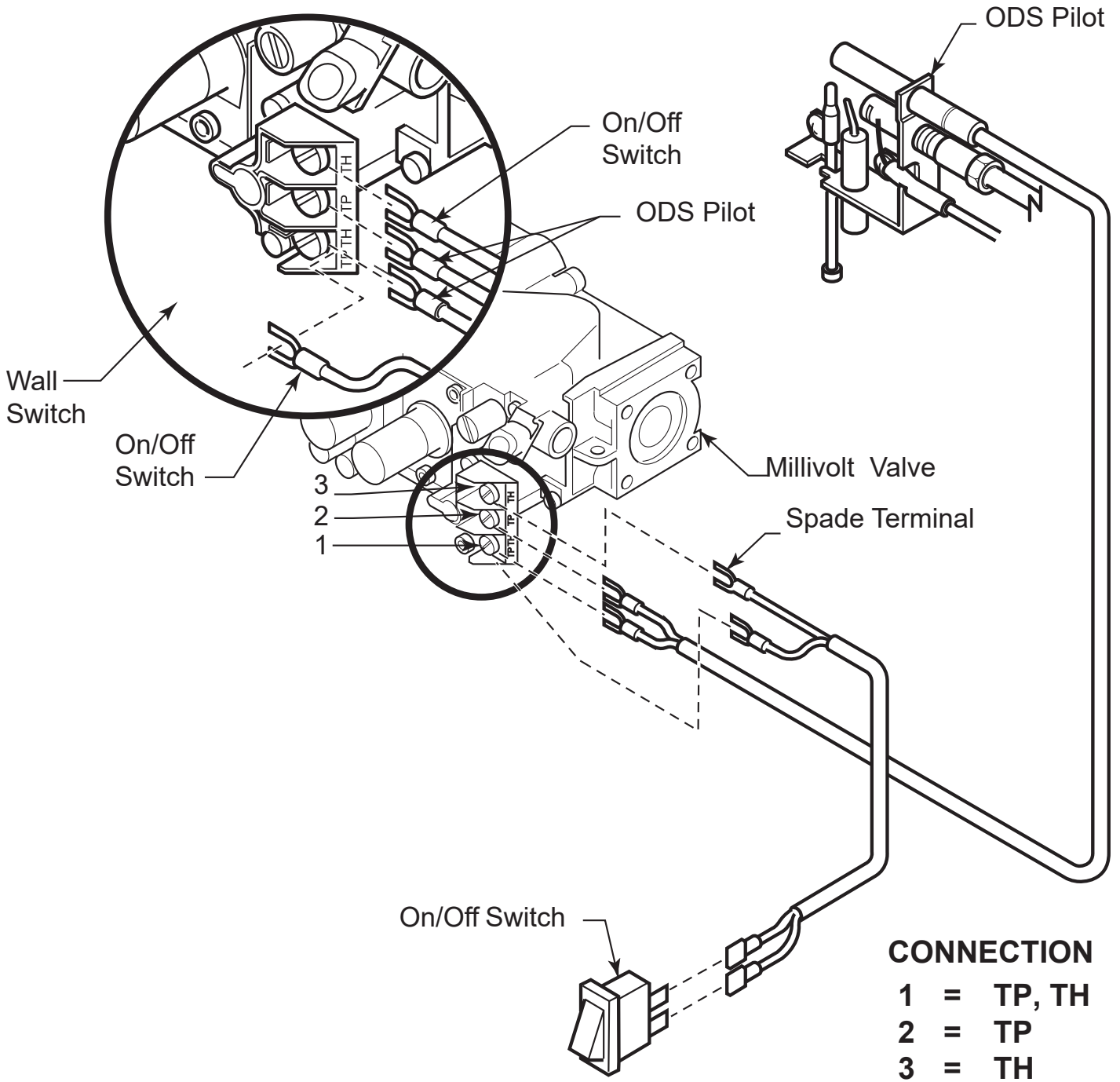

Check Test	To Test	Connect Meter Leads to Terminals	Switch or Thermostat Contacts	Meter Reading Should Be
A	Complete System	1 & 3	Closed	Closed
B	Thermopile	1 & 2	Open	Open

WARNING:

POSITIONING OF THE LOGS IS CRITICAL TO THE SAFE AND CLEAN OPERATION OF THIS HEATER. SOOTING AND OTHER PROBLEMS MAY RESULT IF THE LOGS ARE NOT PROPERLY AND FIRMLY POSITIONED IN THE APPLIANCE. NEVER ADD ADDITIONAL LOGS OR EMBELLISHMENTS SUCH AS PINE CONES, GLOWING EMBERS (ROCK WOOL) TO THE HEATER. ONLY USE THE LOGS SUPPLIED WITH THE UNIT. FAILURE TO POSITION THE PARTS IN ACCORDANCE WITH DIAGRAMS BELOW OR TO USE ONLY PARTS SPECIFICALLY APPROVED FOR THIS HEATER MAY RESULT IN PROPERTY DAMAGE OR PERSONAL INJURY.

Before you begin - This unit is supplied with five ceramic fiber logs. Do not handle these logs with your bare hands. Always wear gloves to prevent skin irritation from ceramic fibers. After handling the logs, wash your hands gently with soap and water to remove any traces of fibers.

NOTE: When placing logs DO NOT cover the burner ports.

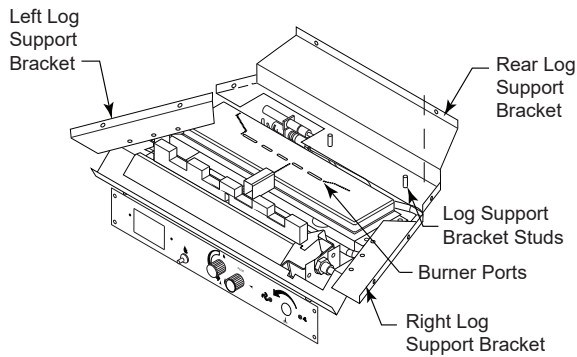

1. To install the back log (#1), position on rear log support bracket and then press down over studs.

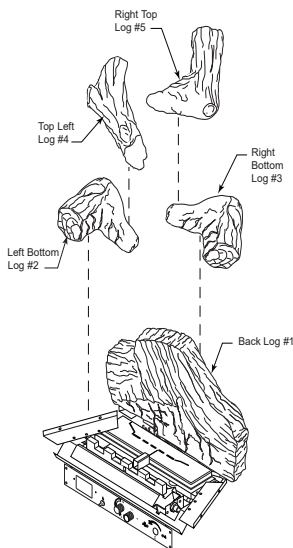

2. Install left bottom log (#2) on left log support bracket in front of back log.

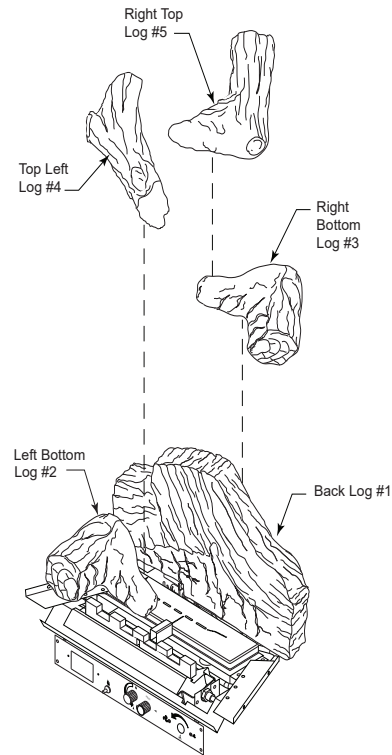

3. Install right bottom log (#3) on right log support bracket in front of back log.

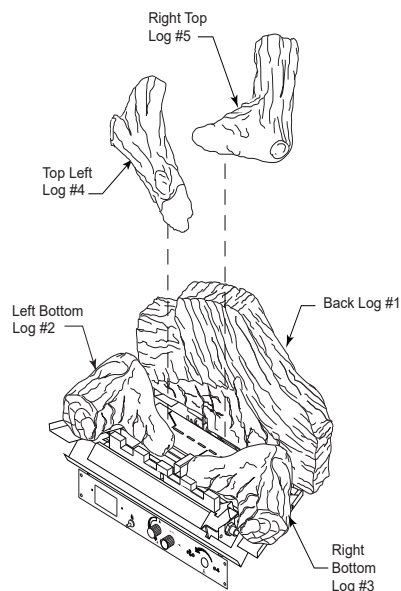

4. Install top left log (#4) on top of left bottom log.

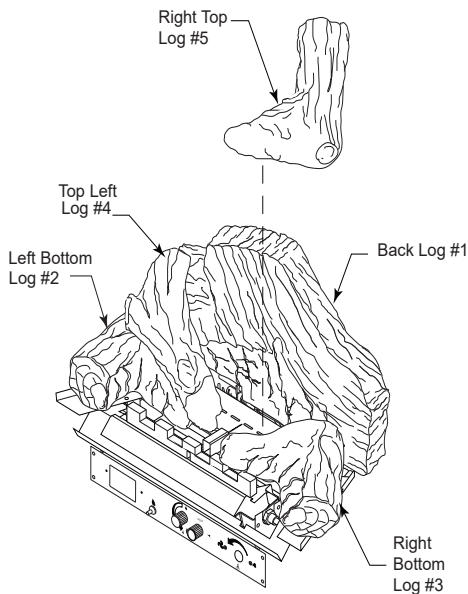

5. Install top right log (#5) on top of right bottom log.

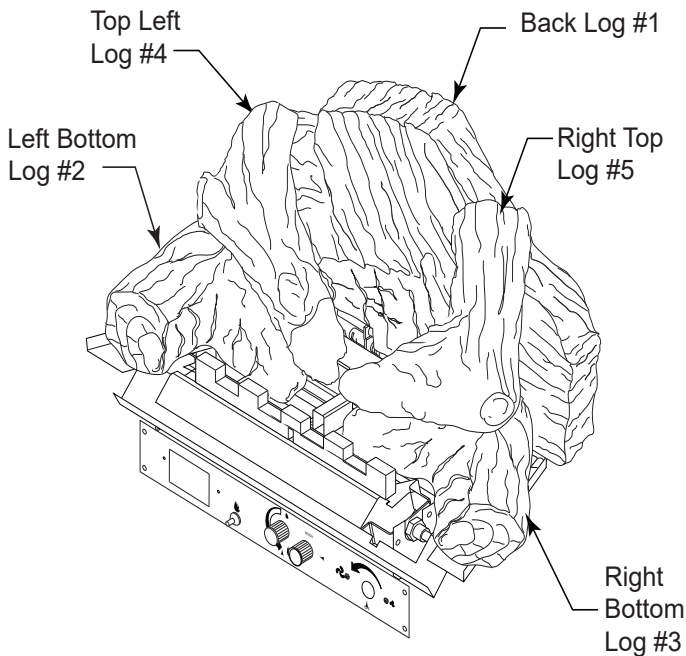

CAUTION:
DURING INITIAL OPERATION OF THE NEW HEATER, BURNING LOGS WILL GIVE OFF A PAPER BURNING SMELL AND ORANGE FLAMES WILL BE PRESENT. SIMPLY OPEN THE WINDOWS FOR A FEW HOURS TO VENT THE ODOR.

GLOWING EMBERS (ROCK WOOL) PLACEMENT

Provided with your log set is a package of glowing embers (rock wool). Break up the glowing embers into small dime sized pieces or for a finer finish use a metal wire brush. Place it over the small holes (ports) located on the burner pan. Cover the entire section of holes (ports). *Replacement of loose (glowing embers) must be purchased from the original manufacturer and application of excess loose material may adversely affect the performance of the heater. NOTE: Wash your hands immediately after coming in contact with wool material. In some cases the wool can cause slight itching or burning, avoid any contact with eyes.

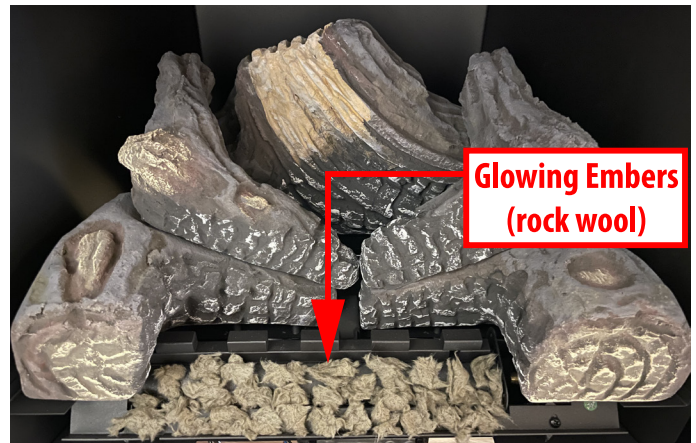

WARNING:
ALL PREVIOUSLY APPLIED LOOSE MATERIAL MUST BE REMOVED PRIOR TO REPLACEMENT. DO NOT COVER THE AIR CHANNELS WITH THE GLOWING EMBERS.

FLAME APPEARANCE

Flames from the pilot, front and rear burner should be visually checked as soon as the heater is installed. In addition, periodically check the flames visually during operation.

PILOT FLAME

The pilot flame must always be present when the heater is in operation. It should just touch the top of the thermocouple tip for natural. Refer to the figure below for correct pilot flame.

If the pilot flame does not touch the thermocouple, then the burners cannot function reliably. Refer to the figure below for incorrect shape of pilot flame.

MILLIVOLT CONTROL

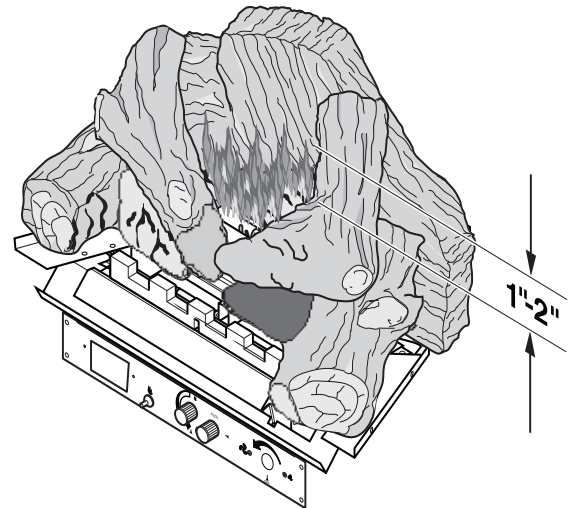
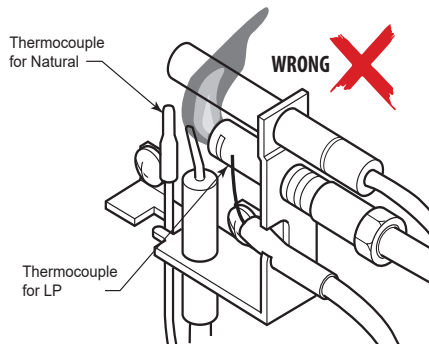
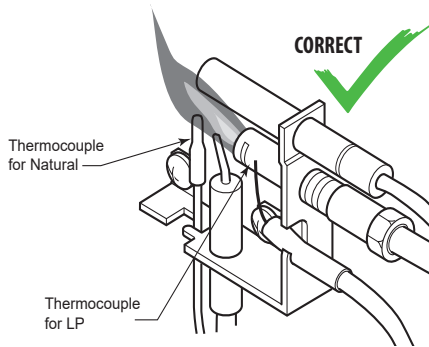

BURNER FLAME

In normal operation at full rate after 15 minutes, the following flame appearances should be observed: The left and right rear flames should be yellow and extend 1" - 2" above middle logs. The yellow flames should not contact the logs. NOTE The flames and embers will be an opaque orange color during the burn off time.

OPERATION

OPERATING INSTRUCTIONS

Avoid any drafts that alter burner flame patterns. Do not allow fans to blow directly into the stove. Do not place a blower inside the burn area of the stove. Ceiling fans may create drafts that alter flame patterns. Sooting and improper burning will result. During manufacturing, fabricating and shipping, various components of this appliance are treated with certain oils, films or bonding agents. These chemicals are not harmful, but may produce annoying smoke and smells as they are burned off during the initial operation of the appliance, possibly causing headaches or eye or lung irritation. This is a normal and temporary occurrence. The initial break-in operation should last two to three hours with the burner at the highest setting. Provide maximum ventilation by opening windows or doors to allow odors to dissipate. Any odors remaining after this initial break-in will be slight and will disappear with continued use.

For Your Safety Read Before Lighting

WARNING:

IF YOU DO NOT FOLLOW THESE INSTRUCTION EXACTLY, A FIRE OR EXPLOSION MAY RESULT CAUSING PROPERTY DAMAGE, PERSONAL INJURY OR LOSS OF LIFE.

- A. This appliance is equipped with an ignition device which automatically lights the pilot. If the piezo is not working properly, refer to Match Lighting instructions.
- B. **BEFORE OPERATING** smell all around the appliance area for gas. Be sure to smell next to the floor because some gas is heavier than air and will settle on the floor.

WHAT TO DO IF YOU SMELL GAS:

- Turn off all gas to the appliance.
- Open windows.
- Do not attempt to light any appliance.
- Do not touch any electric switch; do not use any phone in your building.
- Immediately call your gas supplier from a neighbor's phone. Follow the gas supplier's instructions.

If you cannot reach your gas supplier, call the fire department.

- C. Use only your hand to push in, or turn the gas control knob. Never use tools. If the knob will not push in or turn by hand, don't try to repair it. Call a qualified service technician. Force or attempted repair may result in a fire or explosion.

- D. Do not use this appliance if any part of it has been under water. Immediately call a qualified service technician to inspect the appliance and to replace any part of the control system and any gas control that has been under water.

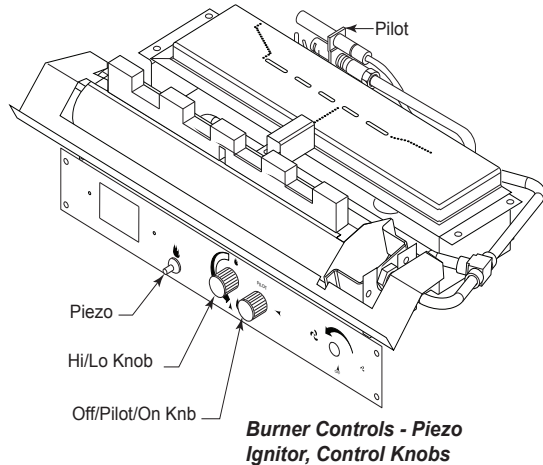

11. If the heater will not operate, follow the instructions "To Turn Off Gas To Appliance" and call your supplier.
12. Wait (30) thirty seconds before readjusting the heater when the control knob has been turned down to a lower setting.

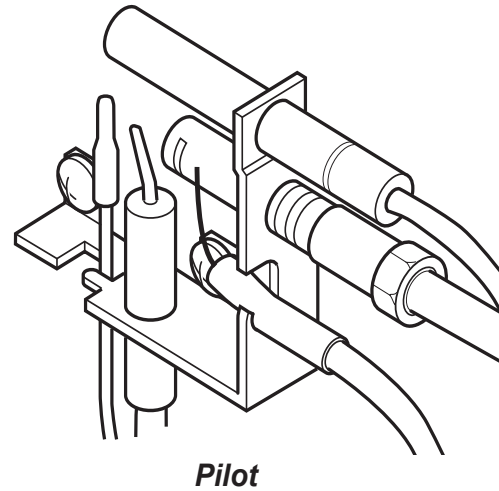

MILLIVOLT CONTROL LIGHTING INSTRUCTIONS

1. STOP! Read All Labels.
2. Make sure the manual shutoff valve is fully open.
3. This heater is equipped with an ignition device (piezo) which automatically lights the pilot. If the pilot will not light using the piezo ignitor refer to the manual lighting procedure.
4. Turn gas control knob clockwise to the "OFF" position, set the thermostat to lowest setting and turn the ON/OFF switch to the "OFF" position.
5. Wait five (5) five minutes to clear out any gas. Then smell for gas, including near the floor. If you smell gas, STOP! Follow "B" in the safety information label. If you don't smell gas, go to the next step.
6. From the "OFF" position, turn the gas control knob counterclockwise to the "IGN" position. Push in the control knob for (5) five second.
7. With the control knob pushed in, push in and release the pieso ignitor button to light the pilot.
8. Continue pushing the control knob in for a further (60) sixty seconds to prevent the flame detector from shutting off the gas while the probe is warming up. Release the control knob.
9. Turn the gas control knob counterclockwise to the "ON" position.
10. After the pilot has been lit for one minute, the burners can be turned on. Turn the On/Off switch to the "ON" position and adjust thermostat to desired setting.

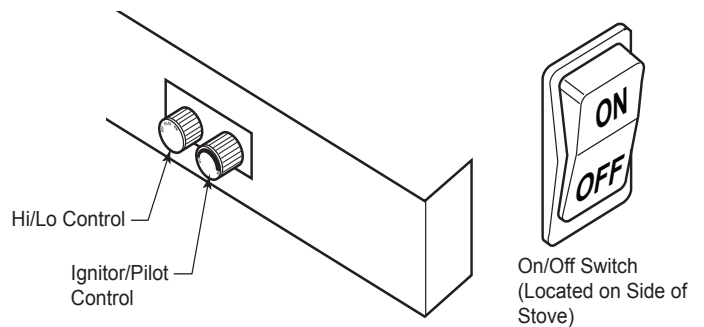

TO TURN OFF GAS TO HEATER

1. Turn gas control knob clockwise to the "OFF" position. Do not force.
2. Turn On/Off switch to the "OFF" position and/or set the thermostat (if present) to the lowest setting.
3. If applicable: Turn off all electric power to the appliance.

MANUAL LIGHTING INSTRUCTIONS

1. Open stove door. Remove any items necessary for easy access to the pilot (for example: logs, screens, etc.).
2. Follow appropriate lighting instructions found previously. Instead of pushing and releasing the piezo button, light a match and hold the flame to the end of the pilot and ignite the pilot.
3. After control knob has been released and pilot stays lit, reinstall any items that were removed for pilot access.

4. Call a qualified service technician for repair or replacement of the piezo ignitor.

CLEANING AND SERVICING

WARNING:

TURN OFF THE HEATER AND ALLOW TO COOL BEFORE CLEANING. DISCONNECT THE ELECTRICAL POWER BEFORE CLEANING OR SERVICING.

Annual inspection and cleaning by your dealer or qualified service technician is recommended to prevent malfunction and/or sooting. Remove logs, handle carefully by holding gently at each end. Gloves are recommended to prevent skin irritation from ceramic fibers. If skin becomes irritated, wash gently with soap and water. Refer to manual for correct log placement.

Periodic Cleaning - See parts diagram for location of items discussed below.

- Do not use cleaning fluid to clean logs or any part of the heater.
- Brush logs with a soft bristle brush or vacuum with a brush attachment.

- Vacuum loose particles and dust from the front and rear burners, control, piezo covers and grate weldment.
- Inspect and clean the burner air intake holes. Remove lint or particles with a vacuum, brush, or some pipe cleaners. Failure to keep air intake holes clean will result in sooting and poor combustion.
- The external case should be dusted and wiped with a moist cloth.

Annual Cleaning /Inspection - Refer to parts diagram for location of items.

- Inspect and clean burner air intake holes. Remove lint or particles with a vacuum, brush or some pipe cleaners. Failure to keep the air intake holes clean will result in sooting and poor combustion.
- Inspect and clean all burner ports.
- Inspect ODS pilot for operation and accumulation of lint at air intake holes.
- Verify flame pattern and log placement for proper operation.
- Verify smooth and responsive ignition of main burner and rear burner.

HOW TO ORDER REPAIR PARTS

CONTACT YOUR DEALER OR INSTALLER FOR PARTS AND SERVICE

The information in this owner’s manual is specific to your unit. When ordering replacement parts the information in this manual will help to ensure the correct items are ordered. Before contacting customer service write down the model number and the serial number of this unit. That information can be found on the certification label attached to the back of the unit. Other information that may be needed would be the part number and part description of the item(s) in question. Part numbers and descriptions can be found in the “Repair Parts” section of this manual. Once this information has been gathered you can contact your EverWarm dealer or visit www.cuiheat.com

Model Information			
Model Number		Dealer’s Name	
Serial Number		Dealer’s Phone Number	

TROUBLESHOOTING

WARNING: TURN THE APPLIANCE "OFF" AND ALLOW TO COOL BEFORE SERVICING. ONLY A QUALIFIED SERVICE PERSON SHOULD SERVICE AND REPAIR THE HEATER.

PROBLEM	POSSIBLE CAUSE	REMEDY
When the ignitor button is pressed, there is no spark at ODS/pilot.	Ignitor electrode positioned wrong.	Replace ignitor.
	Ignitor electrode is broken.	Replace ignitor.
	Ignitor electrode not connected to the ignitor cable.	Reconnect ignitor cable.
	Ignitor cable pinched or wet.	Free ignitor cable if pinched by any metal or tubing. Keep ignitor cable dry.
	Broken ignitor cable.	Replace ignitor cable.
	Bad piezo ignitor.	Replace piezo ignitor.
Appliance produces unwanted odors.	Appliance burning vapors from paint, hair spray, glues, etc.	Ventilate room. Stop using odor causing products while heater is running.
	Gas leak.	Locate and correct all leaks.
	Initial burn off.	Ventilate room and turn unit on high until odor is gone. Odor should be gone after 6 hours of continuous use.
Appliance shuts off during use.	Not enough fresh air is available for ODS/ pilot to operate.	Open window and/or door for ventilation.
	Low line pressure.	Contact local gas company.
	ODS/pilot is partially clogged.	Clean ODS/pilot.
	Defective Thermopile.	Check pilot flame, check wire connections, check output, should be 325 millivolts across TH/TP and TP Terminals with On/Off switches Off.
	Restrictions in incoming air flow.	Check for bottom riser on glass door, sunken fireplace, excessive lava rock/cinders densely packed against grate.
Gas odor even when control knob is in OFF position.	Gas leak.	Locate and correct all leaks.
	Control valve defective.	Replace control valve.

WARNING: IF THE GAS QUALITY IS BAD, YOUR PILOT MAY NOT STAY LIT, THE BURNERS MAY PRODUCE SOOT AND THE HEATER MAY BACKFIRE WHEN LIT. IF THE GAS QUALITY OR PRESSURE IS LOW, CONTACT YOUR LOCAL GAS SUPPLIER IMMEDIATELY.

PROBLEM	POSSIBLE CAUSE	REMEDY
ODS/pilot lights, but flame goes out when control knob is released.	Control knob not fully pressed in.	Press in control knob fully.
	Control knob not pressed in long enough.	After ODS/pilot lights, keep control knob pressed in for 30 seconds.
	Manual shutoff valve not fully open.	Fully open manual shutoff valve.
	Thermocouple connection loose at control valve.	Hand tighten thermocouple connection until snug, then tighten 1/4 turn more.
	Pilot flame not touching thermocouple, which allows thermocouple to cool, causing pilot flame to go out. This problem could be caused by either low gas pressure, or a dirty or partially clogged ODS/pilot.	Contact local gas company. Clean pilot with vacuum cleaner.
	Thermocouple damaged.	Replace pilot assembly.
	Control valve damaged.	Replace control valve.
Burner does not light after ODS/pilot is lit.	Burner orifice is clogged.	Clean orifice.
	Burner orifice diameter is too small.	Replace burner orifice.
	Inlet gas pressure is too low.	Contact qualified service person
Burner backfires during combustion.	Manifold pressure is too low. Burner orifice is clogged.	Contact local gas company. Clean burner or replace burner orifice.
Slight smoke or odor during initial operation.	Burner orifice is clogged or damaged.	Clean burner or replace burner orifice.
	Burner is damaged.	Replace burner.
	Gas regulator defective.	Replace gas regulator.
Logs appear to smoke after initial operation.	Vapors from paint or curing process of logs.	Problem will stop after a few hours of operation. Run the heater with the damper open if you have one, or open a window for the first few hours.
	Vapors or smoke continue after heater has run with damper or window open for several hours.	Log heater is intended to be smokeless. Turn OFF heater and call qualified service person.
Heater produces a whistling noise when burner is lit.	Turning control knob to HIGH position when burner is cold.	Turn control knob to LOW position and let warm up for a minute.
	Air in gas line.	Operate burner until air is removed from line. Have gas line checked by local gas company.
	Dirty or partially clogged burner orifices.	Clean burner or replace burner orifice
No gas to pilot.	LP-regulator shut down due to inlet pressure too high.	Verify LP tank regulator is installed and set at 11" to 13" w.c. Replace regulator on heater.

REPLACEMENT PARTS

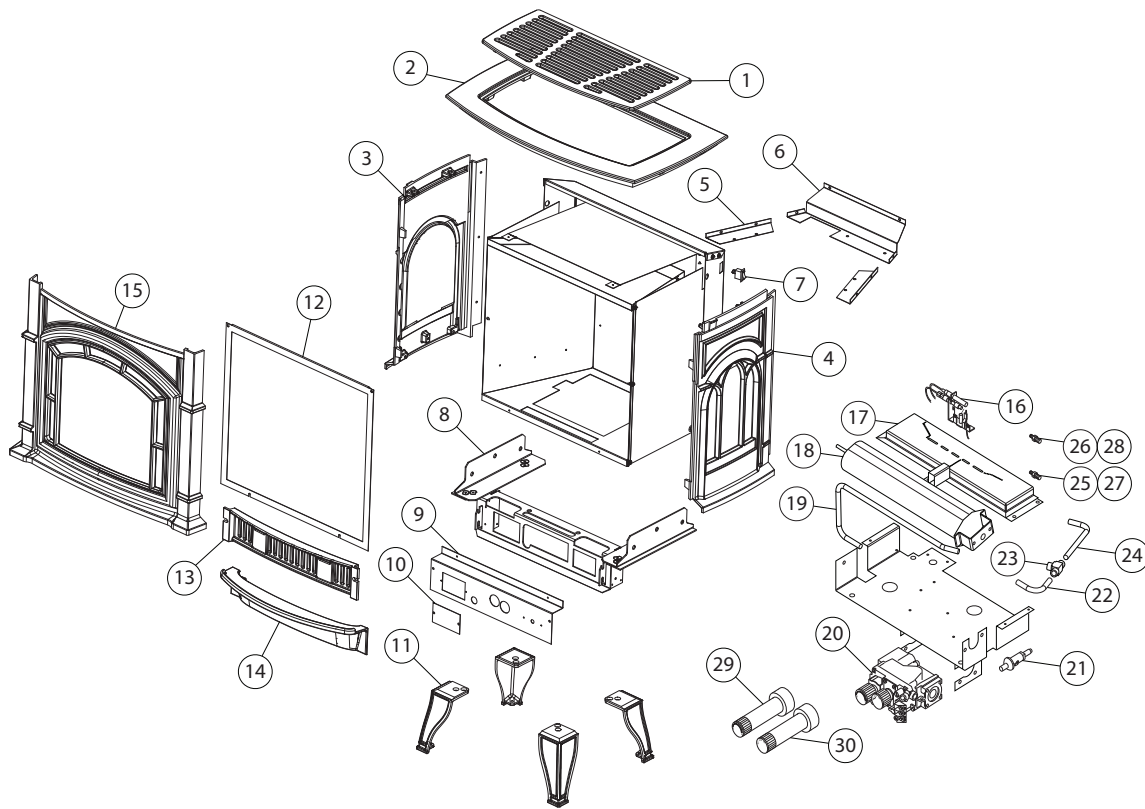

Key	Part #	Description	Qty
1	40861	VF Grate	1
2	40860	VF Top	1
3	40857	Left Side	1
4	40856	Right Side	1
5	27225	Side Log Retainer	2
6	27222	Rear Log Support	1
7	C42373	On/Off Switch	1
8	892537.13	Base Assembly	1
9	892537.7	Control Panel	1
10	892537.8	Control Cover	1
11	40854	Leg	1
12	610120	Front Screen Assembly	1
13	40859	Ash Bar	1
14	40858	Ash Lip	1
15	40855	Front	1
16	89921	ODS Pilot Assembly (NAT)	1
	89922	ODS Pilot Assembly (LP)	1
17	81211-06	Rear Burner	1

Key	Part #	Description	Qty
18	81211-05	Front Burner	1
19	81211-12	VF Valve Tube	1
20	81202	Control Valve (LP)	1
	81198	Control Valve (NAT)	1
21	89761	Piezo Ignitor	1
22	81211-14	VF Front Burner Tube	1
23	81211-11	5/16 Union Tee	1
24	81211-13	VF Rear Burner Tube	1
25	81210-08	Rear Burner Orifices (NAT) #47	1
26	81210-08	Front Burner Orifices (NAT) #47	1
27	81211-16	Rear Burner Orifices (LP) #56	1
28	81211-17	Front Burner Orifices (LP) #55	1
29	81200	Hi/Lo Knob	1
30	81199	Off/Pilot/On Knob	1
31	894111	Filler Plate (not shown)	1
32	892463	Glowing Embers (not shown)	1

IN ORDER TO MAINTAIN WARRANTY, COMPONENTS MUST BE REPLACED USING ORIGINAL MANUFACTURERS PARTS PURCHASED THROUGH YOUR DEALER OR DIRECTLY FROM THE APPLIANCE MANUFACTURER. USE OF THIRD PARTY COMPONENTS WILL VOID THE WARRANTY.

It is recommended that your heating system is serviced regularly and that the appropriate Service Interval Record is completed.

SERVICE PROVIDER

Before completing the appropriate Service Record below, please ensure you have carried out the service as described in the manufacturer's instructions. Always use the manufacturer's specified spare part when replacement is necessary.

Service 01 Date: _____
 Technician Name: _____
 License No.: _____
 Company: _____
 Telephone No.: _____
 Stove Inspected: Chimney Swept:
 Items Replaced: _____

Service 02 Date: _____
 Technician Name: _____
 License No.: _____
 Company: _____
 Telephone No.: _____
 Stove Inspected: Chimney Swept:
 Items Replaced: _____

Service 03 Date: _____
 Technician Name: _____
 License No.: _____
 Company: _____
 Telephone No.: _____
 Stove Inspected: Chimney Swept:
 Items Replaced: _____

Service 04 Date: _____
 Technician Name: _____
 License No.: _____
 Company: _____
 Telephone No.: _____
 Stove Inspected: Chimney Swept:
 Items Replaced: _____

Service 05 Date: _____
 Technician Name: _____
 License No.: _____
 Company: _____
 Telephone No.: _____
 Stove Inspected: Chimney Swept:
 Items Replaced: _____

Service 06 Date: _____
 Technician Name: _____
 License No.: _____
 Company: _____
 Telephone No.: _____
 Stove Inspected: Chimney Swept:
 Items Replaced: _____

Service 07 Date: _____
 Technician Name: _____
 License No.: _____
 Company: _____
 Telephone No.: _____
 Stove Inspected: Chimney Swept:
 Items Replaced: _____

Service 08 Date: _____
 Technician Name: _____
 License No.: _____
 Company: _____
 Telephone No.: _____
 Stove Inspected: Chimney Swept:
 Items Replaced: _____

LIMITED LIFETIME WARRANTY

Everwarm extends the following limited warranty for Everwarm gas appliances that are purchased from an Everwarm authorized dealer.

Components Covered	Warranty Period	
	Labor	Limited Lifetime*
Blowers, electronic components, valves and remotes	3 yrs	3 yrs
Logs and firebrick panels	3 yrs	10 yrs
Burners	3 yrs	Limited Lifetime
Combustions chamber, heat exchangers and factory-installed glass	3 yrs	Limited Lifetime
Castings and baffles	3 yrs	5 yrs
Accessories	3 yrs	2 yrs
Purchased replacement parts		90 days

WARRANTY COVERAGE

This warranty is non-transferable and is made to the original retail purchaser; provided the purchase was made through an authorized Everwarm dealer, and subject to the conditions, exclusions and limitations contained herein. After installation, if covered components manufactured by Everwarm are found to be defective in materials or workmanship during the applicable warranty period, Everwarm will, at its option, repair or replace the covered components. Everwarm, at its own discretion, may fully discharge all its obligations under such warranties by replacing the product itself or refunding the verified purchase price of the product itself. The maximum amount recoverable under this warranty is limited to the purchase price of the product. This warranty is subject to conditions, exclusions and limitations as described below.

WARRANTY PERIOD

Warranty coverage begins on the date of original purchase. In the case of new home construction, warranty coverage begins on the date of first occupancy of the dwelling or six months after the sale of the product by an independent, authorized Everwarm dealer/ distributor, whichever occurs earlier. The warranty shall commence no later than 18 months following the date of appliance shipment from Everwarm, regardless of the installation or occupancy date. The warranty period for parts and labor for covered components is provided in the following table. The term "Limited Lifetime" in the table below is defined as 20 years from the beginning date of warranty coverage.

These time periods reflect the minimum expected life of the designated components under normal operating conditions. The warranty for components replaced under the terms of this warranty shall extend only for the remaining period of the original warranty. The warranty for products replaced under the terms of this warranty shall extend only for the remaining period of the original warranty.

WARRANTY CONDITIONS

- This warranty only covers Everwarm appliances that are purchased through an Everwarm authorized dealer or distributor. A list of Everwarm authorized dealers is available on the Everwarm branded websites.
- This warranty is only valid while the Everwarm appliance remains at the site of original installation.
- Contact your installing dealer for warranty service. If the installing dealer is unable to provide necessary parts, contact the nearest Everwarm authorized dealer or supplier. You may be responsible for additional service fees if you are seeking warranty service from a dealer other than the dealer from whom you originally purchased the product.
- Check with your dealer in advance for any costs to you when arranging a warranty call. Travel and shipping charges for parts are not covered by this warranty.

WARRANTY EXCLUSIONS

Damages resulting from

- Failure to install, operate, or maintain the appliance in accordance with the installation instructions, operating instructions, and listing agent identification label furnished with the appliance.
- Failure to install the appliance in accordance with local building codes and/or authorities having jurisdiction.
- Shipping or improper handling.
- Improper operation, abuse, misuse, continued operation with damaged, corroded or failed components, accident, or improperly/incorrectly performed repairs.
- Environmental conditions, inadequate ventilation, negative pressure, or drafting caused by tightly sealed constructions, insufficient make-up air supply, or handling devices such as exhaust fans, forced air furnaces or other such causes.
- Use of fuels other than those specified in the operating instructions.
- Installation or use of components not supplied with the appliance or any other components not expressly authorized and approved by Everwarm Hearth Products.

- Modification of the appliance not expressly authorized and approved by Everwarm in writing.
- Interruptions or fluctuations of electrical power supply to the appliance.
- Changes in surface finishes because of normal use. As a heating appliance, some changes in color of interior and exterior surface finishes may occur. This is not a flaw and is not covered under warranty.
- Damage to printed, plated, or enameled surfaces caused by fingerprints, accidents, misuse, scratches, melted items, or other external sources and residues left on the plated surfaces (e.g., from the use of abrasive cleaners or polishes).
- Repair or replacement of parts that are subject to normal wear and tear during the warranty period. These parts include but are not limited to paint, door gaskets, grates, batteries, and the discoloration of glass.
- Any part of a pre-existing fireplace system in which an insert or a decorative gas appliance is installed.

WARRANTY VOIDED IF

- The appliance has been over-fired or operated in atmospheres contaminated by damaging chemicals. Over-firing can be identified by, but not limited to, warped plates or tubes, rust colored cast iron, bubbling, cracking and discoloration of steel or enamel finishes.
- The appliance is subjected to prolonged periods of dampness or condensation.
- There is any damage to the appliance or other components due to water or weather damage which is the result of, but not limited to, improper chimney or venting installation.

LIABILITY LIMITATIONS

The original owner's exclusive remedy and Everwarm's sole obligation under this warranty, under any other warranty, express or implied, or in contract, tort or otherwise, shall be limited to replacement, repair, or refund, in Everwarm's sole and absolute discretion. In no event will Everwarm be liable for any incidental or consequential damages. THE LIMITED WARRANTY SET FORTH HEREIN IS THE SOLE WARRANTY PROVIDED TO PURCHASER AND IS IN LIEU OF ALL OTHER WARRANTIES AND REPRESENTATIONS, EXPRESS OR IMPLIED. EVERWARM MAKES NO REPRESENTATIONS OR WARRANTIES WHATSOEVER, EXPRESS OR IMPLIED, WITH RESPECT TO THE PRODUCT, OTHER THAN (i) THE LIMITED WARRANTY ABOVE, AND (ii) ANY IMPLIED WARRANTIES IMPOSED BY APPLICABLE LAW WHICH CANNOT BE WAIVED OR DISCLAIMED UNDER APPLICABLE LAW. ALL OTHER WARRANTIES OF ANY KIND, INCLUDING WITHOUT LIMITATION IMPLIED WARRANTIES OF MERCHANTABILITY AND FITNESS FOR A PARTICULAR PURPOSE, ARE HEREBY DISCLAIMED AND EXCLUDED TO THE FULLEST EXTENT NOT PROHIBITED BY APPLICABLE LAW. This Limited Warranty gives the purchaser specific legal rights; a purchaser may have other rights depending upon where he or she resides. Some states do not allow the exclusion or limitation of special, incidental or consequential damages, or state law may affect the duration of limitations, so the above exclusion and limitations may not be applicable.